

# ASTI CEILING HOOK

## ARCHITECTURAL SPECIFICATIONS MATERIAL: ZINC ALLOY 5

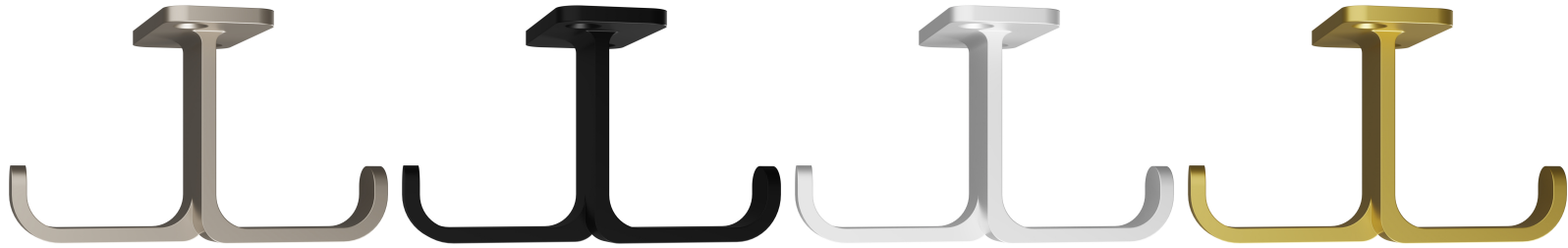

- |   |   |  |   |
|---|---|--|---|
| <ul style="list-style-type: none"><li>• <b>PART NUMBER:</b><br/><b>ASTI-HOOK-SN</b></li><li>• <b>FINISH (STANDARD):</b><br/>Satin Nickel</li><li>• <b>FINISHING PROCESS:</b><br/>Electroplating</li></ul> | <ul style="list-style-type: none"><li>• <b>PART NUMBER:</b><br/><b>ASTI-HOOK-MB</b></li><li>• <b>FINISH (PREMIUM):</b><br/>Matte Black   Munsell N2</li><li>• <b>FINISHING PROCESS:</b><br/>Electrodeposition Coating</li></ul> | <ul style="list-style-type: none"><li>• <b>PART NUMBER:</b><br/><b>ASTI-HOOK-MW</b></li><li>• <b>FINISH (PREMIUM):</b><br/>Matte White   Munsell N9</li><li>• <b>FINISHING PROCESS:</b><br/>Epoxy Painting</li></ul> | <ul style="list-style-type: none"><li>• <b>PART NUMBER:</b><br/><b>ASTI-HOOK-SG</b></li><li>• <b>FINISH (PREMIUM):</b><br/>Satin Gold   Munsell N9</li><li>• <b>FINISHING PROCESS:</b><br/>Epoxy Painting</li></ul> |
|---|---|--|---|

10% color discrepancy, and custom pricing options apply.

- **MATERIAL:** Zinc Alloy 5
- **FINISHES:** Satin Nickel, Matte Black, Matte White, Satin Gold
- **INCLUDED:** Satin nickel screws (quantity: 2)
- **TESTED:** Rust-resistant and perfect for humid environments
- **CLEANING:** When disinfecting, mist with liquid that is at least 70% alcohol solution in order to maintain product integrity
- **WEIGHT CAPACITY:** 50 lbs

### TOP VIEW

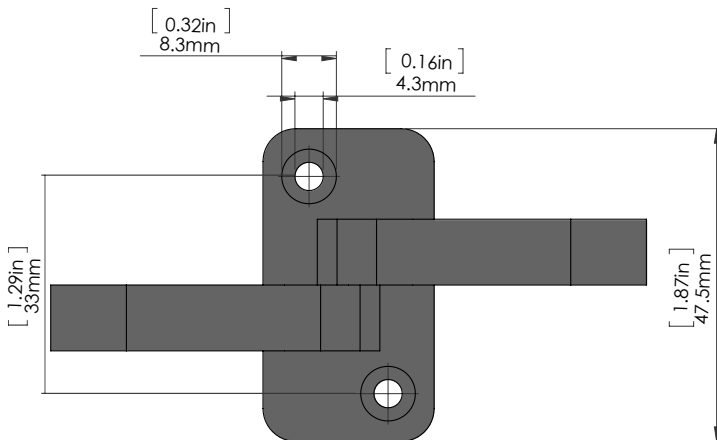

### FRONT VIEW

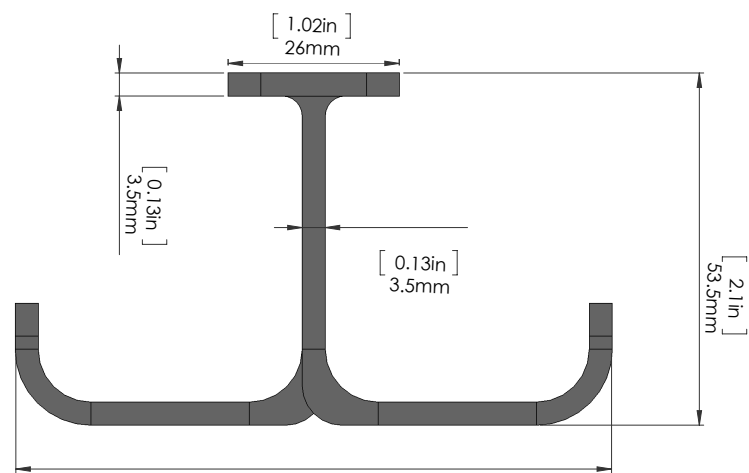

### SCREWS

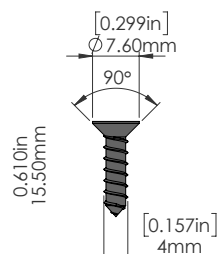

[ 3.56in ]  
90.5mm

Manufactured By:

**KEYLESS.CO**

1825 W. Walnut Hill Ln., Suite 102, Irving, TX 75038, USA | +1 972-331-2770 | info@keyless.co | www.keyless.co | V: 2/25/2021