

ASTI CEILING HOOK

ARCHITECTURAL SPECIFICATIONS MATERIAL: STAINLESS STEEL 304



- **PART NUMBER:**
ASTI-HOOK-B-SS
- **FINISH (STANDARD):**
Brushed Stainless Steel
- **FINISHING PROCESS:**
Electroplating



- **PART NUMBER:**
ASTI-HOOK-MB-SS
- **FINISH (PREMIUM):**
Matte Black | Munsell N2
- **FINISHING PROCESS:**
Electrodeposition Coating



- **PART NUMBER:**
ASTI-HOOK-MW-SS
- **FINISH (PREMIUM):**
Matte White | Munsell N9
- **FINISHING PROCESS:**
Epoxy Painting

10% color discrepancy, and custom pricing options apply.

- **MATERIAL:** Stainless Steel 304
- **FINISHES:** Brushed Stainless Steel, Matte Black, Matte White
- **INCLUDED:** Satin nickel screws (quantity: 2)
- **TESTED:** Rust-resistant and perfect for humid environments
- **CLEANING:** When disinfecting, mist with liquid that is at least 70% alcohol solution in order to maintain product integrity
- **WEIGHT CAPACITY:** 50 lbs

TOP VIEW

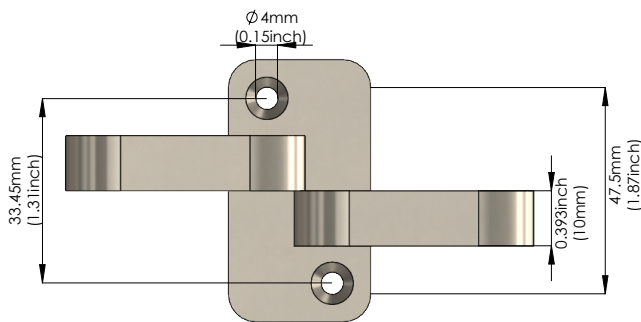

FRONT VIEW

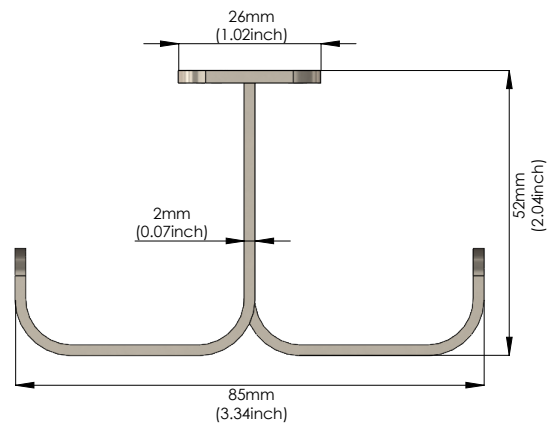

SCREWS

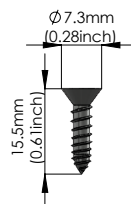

Manufactured By: