

OSLO BENCH LEG

ARCHITECTURAL SPECIFICATIONS

MATERIAL: ALUMINUM 6061

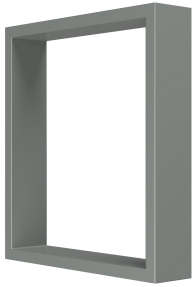

PART NUMBER:
OSLO-LEG-15-MS-AL
 16.5" x 15" (419mm x 381mm)
OSLO-LEG-20-MS-AL
 16.5" x 20" (419mm x 508mm)
FINISH:
 Metallic Silver Pantone #877C
FINISHING PROCESS:
 Powder Coating

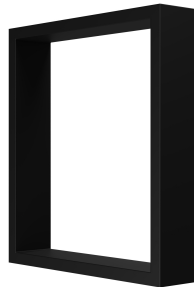

PART NUMBER:
OSLO-LEG-15-MB-AL
 16.5" x 15" (419mm x 381mm)
OSLO-LEG-20-MB-AL
 16.5" x 20" (419mm x 508mm)
FINISH:
 Matte Black Munsell N 2.75
FINISHING PROCESS:
 Powder Coating



PART NUMBER:
O-LEG-15-MW-AL
 16.5" x 15" (419mm x 381mm)
OSLO-LEG-20-MW-AL
 16.5" x 20" (419mm x 508mm)
FINISH:
 Matte White Munsell N 9.25
FINISHING PROCESS:
 Powder Coating

10% color discrepancy, and custom pricing options apply.

HEIGHT: 16.5" (419mm)
WIDTH: Available in both 15" (381mm) or 20" (508mm) width
MATERIAL: Aluminum 6061
FINISHES: Metallic Silver, Matte Black, Matte White
STRENGTH: 2,204 lbs. (1,000 kg) Top Load Resistance per set
BUMPERS: White Plastic bumpers 1.57" x .19" (40mm x 5mm)
TESTED: Rust-resistant and perfect for humid environments
CLEANING: When disinfecting, mist with at least 70% alcohol solution in order to maintain product integrity

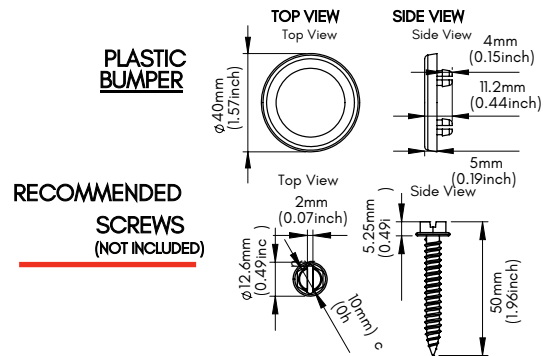

TOP VIEW 20" (508mm)

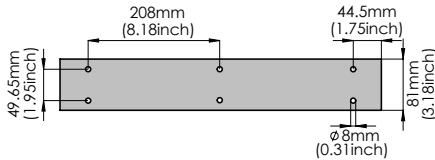

TOP VIEW 15" (381mm)

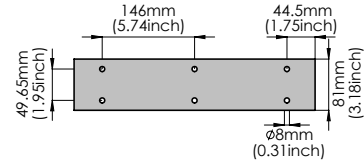

BOTTOM VIEW 20" (508mm)

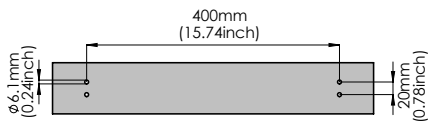

BOTTOM VIEW 15" (381mm)

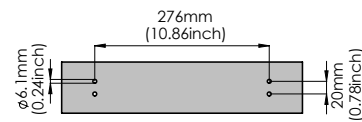

FRONT VIEW 20" (508mm)

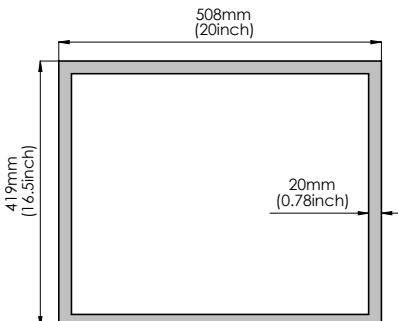

FRONT VIEW 15" (381mm)

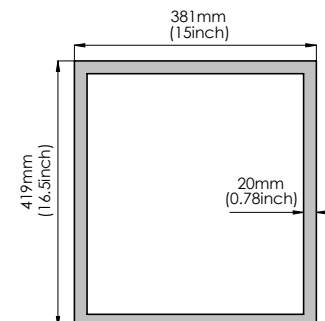

Manufactured By:

KEYLESS.CO

1825 W. Walnut Hill Ln., Suite 102, Irving, TX 75038, USA | +1 972-331-2770 | info@keyless.co | www.keyless.co | V: 3/18/2021

OSLO BENCH LEG

ARCHITECTURALSPECIFICATIONS

MATERIAL: STAINLESS STEEL SUS 304

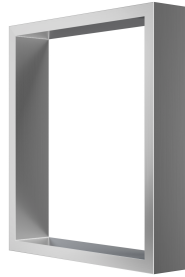

PART NUMBER:

OSLO-LEG-15-B-SS

16.5" x 15" (419mm x 381mm)

PART NUMBER:

OSLO-LEG-20-B-SS

16.5" x 20" (419mm x 508mm)

FINISH: Brushed Stainless Steel

FINISHING PROCESS: polished

10% color discrepancy, and custom pricing options apply.

HEIGHT: 16.5" (419mm)

WIDTH: Available in both 15" (381mm) or 20" (508mm) width

MATERIAL: Stainless Steel SUS 304

FINISH: Brushed Stainless Steel

STRENGTH: 2,204 lbs. (1,000 kg) Top Load Resistance per set

BUMPERS: White Plastic bumpers 1.57" x.19" (40mm x 5mm)

TESTED: Rust-resistant and perfect for humid environments

CLEANING: When disinfecting, mist with at least 70% alcohol solution in order to maintain product integrity

PLASTIC BUMPER

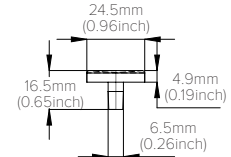

RECOMMENDED SCREWS (NOT INCLUDED)

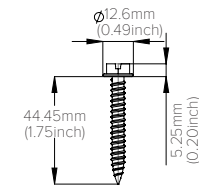

TOP VIEW 20" (508mm)

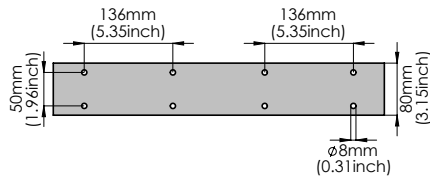

TOP VIEW 15" (381mm)

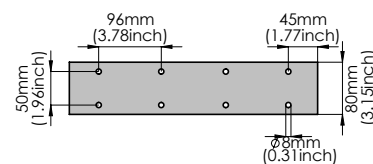

BOTTOM VIEW 20" (508mm)



BOTTOM VIEW 15" (381mm)

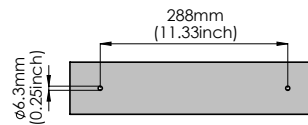

FRONT VIEW 20" (508mm)

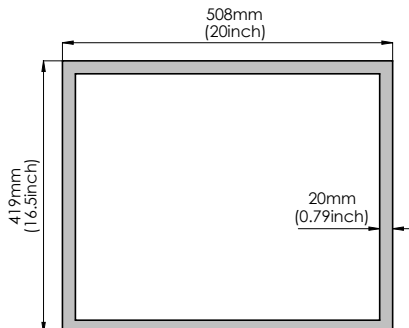

FRONT VIEW 15" (381mm)

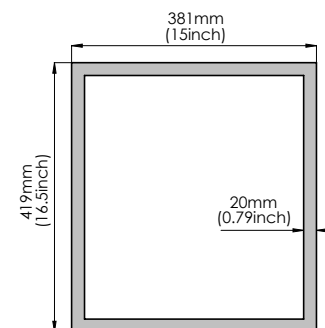

Manufactured By:

KEYLESS.CO

1825 W. Walnut Hill Ln., Suite 102, Irving, TX 75038, USA | +1 972-331-2770 | info@keyless.co | www.keyless.co | V: 3/18/2021