

ASTI CEILING HOOK

ARCHITECTURAL SPECIFICATIONS

MATERIAL: ZINC ALLOY 5



- | | | | |
|--|--|---|---|
| <ul style="list-style-type: none">• PART NUMBER: ASTI-HOOK-SN• FINISH (STANDARD): Satin Nickel• FINISHING PROCESS: Electroplating | <ul style="list-style-type: none">• PART NUMBER: ASTI-HOOK-MB• FINISH (PREMIUM): Matte Black Munsell N2• FINISHING PROCESS: Electrodeposition Coating | <ul style="list-style-type: none">• PART NUMBER: ASTI-HOOK-MW• FINISH (PREMIUM): Matte White Munsell N9• FINISHING PROCESS: Epoxy Painting | <ul style="list-style-type: none">• PART NUMBER: ASTI-HOOK-SG• FINISH (PREMIUM): Satin Gold Pantone #871C• FINISHING PROCESS: Epoxy Painting |
|--|--|---|---|

10% color discrepancy, and custom pricing options apply.

- **MATERIAL:** Zinc Alloy 5
- **FINISHES:** Satin Nickel, Matte Black, Matte White, Satin Gold
- **INCLUDED:** Satin nickel screws (quantity: 2)
- **TESTED:** Rust-resistant and perfect for humid environments

- **CLEANING:** When disinfecting, mist with at least 70% alcohol solution in order to maintain product integrity
- **WEIGHT CAPACITY:** 50 lbs

TOP VIEW

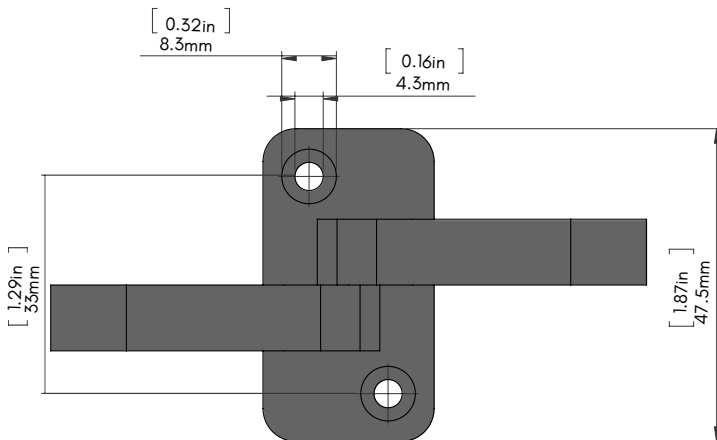

FRONT VIEW

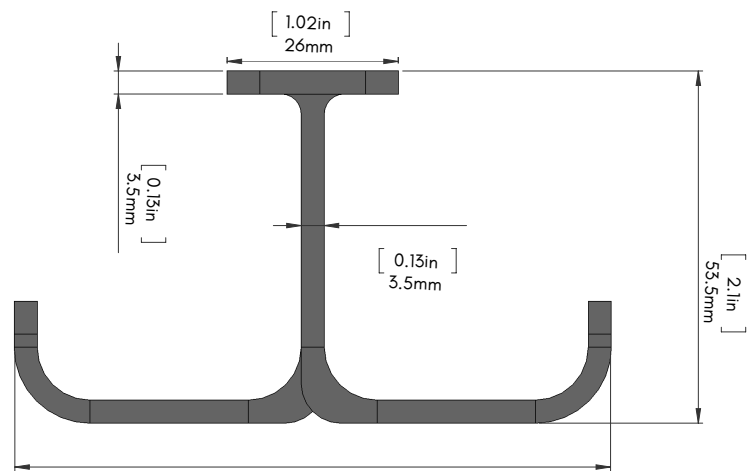

SCREWS (SUS 304)

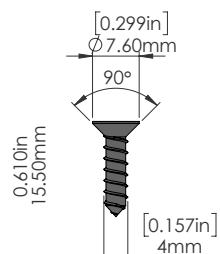

[3.56in]
90.5mm

Manufactured By:

KEYLESS.CO

1825 W. Walnut Hill Ln., Suite 102, Irving, TX 75038, USA | +1 972-331-2770 | info@keyless.co | www.keyless.co | V: 3/4/2021